

Title: TWOS COMPLEMENT ADDER/SUBTRACTOR**Materials:**

[1] 7486

[1] 7483

Procedure:

1. Design the 2s complement adder/subtractor system shown in Fig. 23-1. Use a 7486 for the XOR gates and a 7483 adder IC for the four full adders (FAs).
2. On a separate sheet of paper, **draw** a wiring diagram of your adder/subtractor circuit. Use 1 7486, 1 7483, nine input switches, and four LED output indicator lights. Number all pins.
3. Wire and operate the 2s complement adder/subtractor circuit. Check the 2s complement subtractor mode by doing the sample problems shown in Fig 23-2. The first problem would be placed in the machine as $A_3A_2A_1A_0 = 0111$ and $B_3B_2B_1B_0 = 0011$. The answer on the display should read 0100 (2s complement difference).
4. You must come ready to demonstrate the 2s complement addition and subtractor to your instructor. **Get Instructor's Signature.**

Questions

(there are none – you're done! Congrats – you made it through Incredibly Cruel Torture)

Fig. 23-2**2s Complement Addition Problems**

$$(+4) + (+3) = +7_{10} \qquad 0100 + 0011 = 0111 \text{ (2s comp)}$$

$$(-1) + (-2) = -3_{10} \qquad 1111 + 1110 = 1101 \text{ (2s comp)}$$

$$(+1) + (-3) = -2_{10} \qquad 0001 + 1101 = 1110 \text{ (2s comp)}$$

$$(+5) + (-4) = +1_{10} \qquad 0101 + 1100 = 0001 \text{ (2s comp)}$$

2s Complement Subtraction Problems

$$(+7) - (+3) = +4_{10} \qquad 0111 + 1101 = 0100 \text{ (2s comp diff.)}$$

$$(-8) - (-3) = -5_{10} \qquad 1000 + 0011 = 1011 \text{ (2s comp diff.)}$$

$$(+3) - (-3) = +6_{10} \qquad 0011 + 0011 = 0110 \text{ (2s comp diff.)}$$

$$(-4) - (+2) = -6_{10} \qquad 1100 + 1110 = 1-1- \text{ (2s comp diff.)}$$

2s Complement Inputs
 $A_3A_2A_1A_0$
 $+/- B_3B_2B_1B_0$

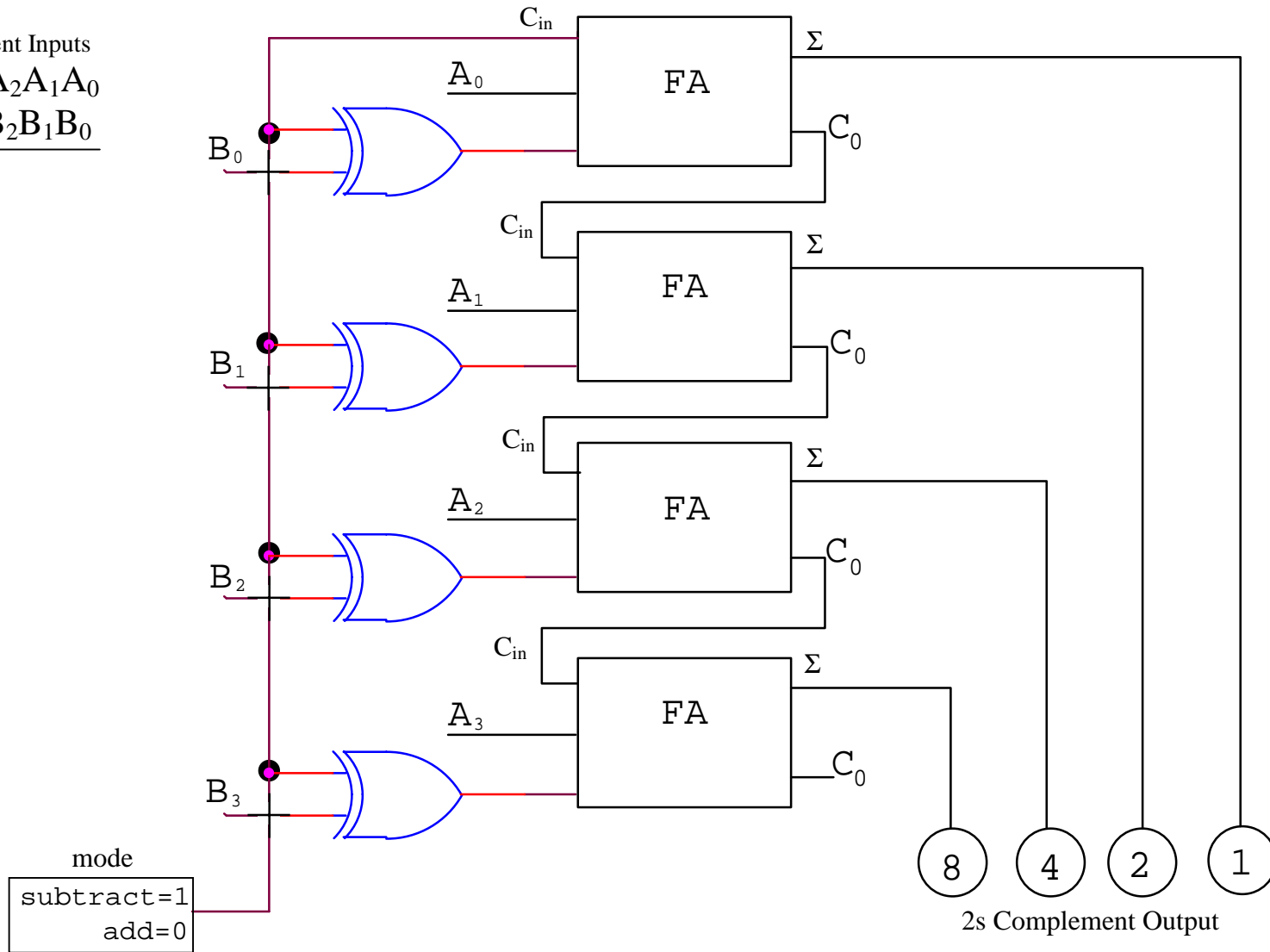

Fig. 23-1